

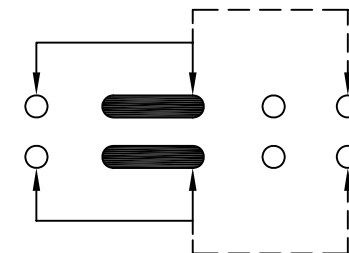

CAD FILE:

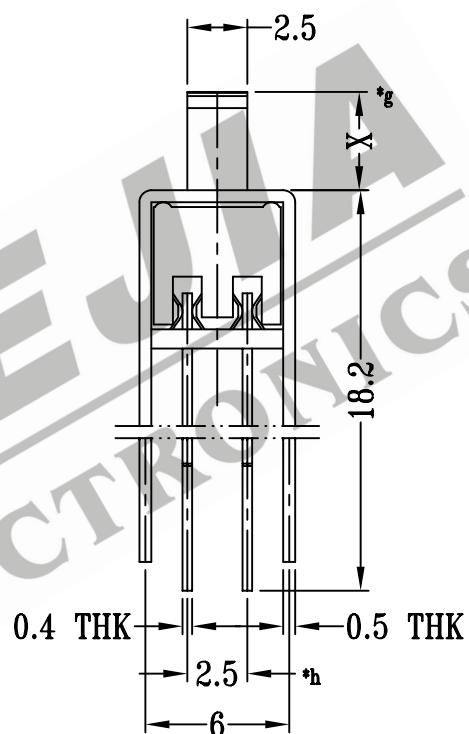

SCHEMATIC (NON-SHORTING)

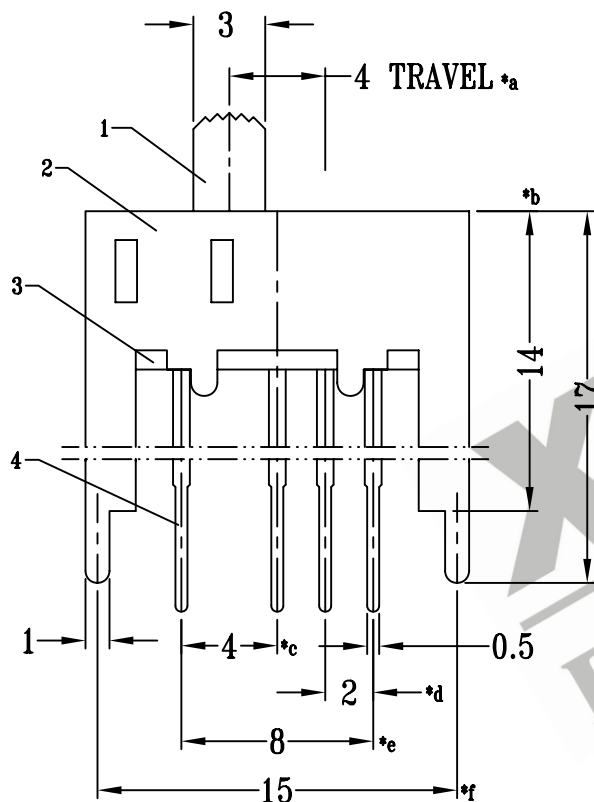
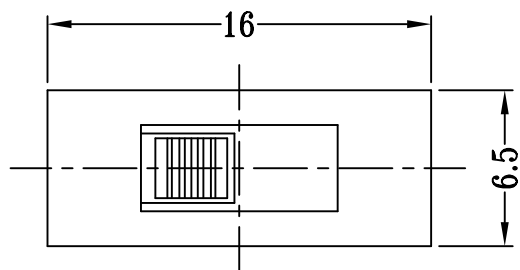
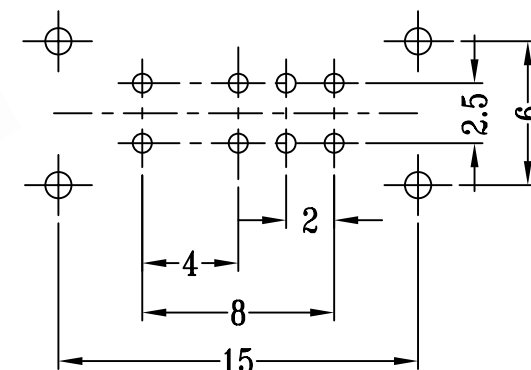

P.C.B LAYOUT

注:带*表示关键尺寸(8个)

NO.	PARTS	MATERIASL	Q'TY	FINISH	TOLERANCE UNLESS SPECIFIED	SHENZHEN XIEJIA ELECTRONICS CO.,LTD.					
8						ISSUE		DATE		DESCRIPTIONS OF REVISION	APPD.
7	STEEL BALL	STEEL	1	NATURAL	WITHIN: 1.5±0.1mm						
6	SPRING	STEEL WIRE	1	TEMPER	OVER : 1.5±0.2mm						
5	CONTACT CLIP	PBS STRIP	2	Ag PLATED							
4	TERMINAL	BRASS STRIP	8	Ag PLATED OVER Ni PLATED							
3	BASE	PHENOLIC RESIN	1	NATURAL	TITLE : VERTICAL SLIDE SWITCH	UNIT : mm		DRWG NO.: XJ-DR-SS22H03-00			
2	FRAME	STEEL STRIP	1	Ni PLATED	MODEL: SS-22H03	SCALE: 3:1		DWN.	ZHOUYU	2002-6-17	
1	KNOB	POM	1	BLACK				CHK'D	FANGYING	2002-6-17	
					ALL MATERIALS MUST BE COMPLIANT TO ROHS			APPD.	KANGXINAN	2002-6-17	